

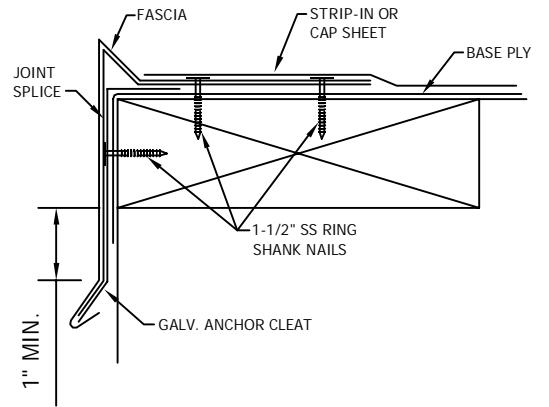

# Installation Guide for SopraBond SPB-G

(For Built Up or Modified Roofs)

ANSI/SPRI ES-1 TESTED



**NOTES:**

- #1 - Isolate all metal parts from ACO treated wood or other galvanically incompatible material with appropriate membrane material.
- #2 - Appliance attachments, such as lightning rods, signs, or antennae that penetrate the water seal, induce a galvanic reaction, or otherwise compromise the effectiveness of the roof edge system, shall be eliminated or isolated to prevent problems per section 8.0 of ANSI/SPRI ES-1. Appliances shall be isolated from or not attached to the roof edge system. Consult the lightning protection system manufacturer for specific attachment instructions.

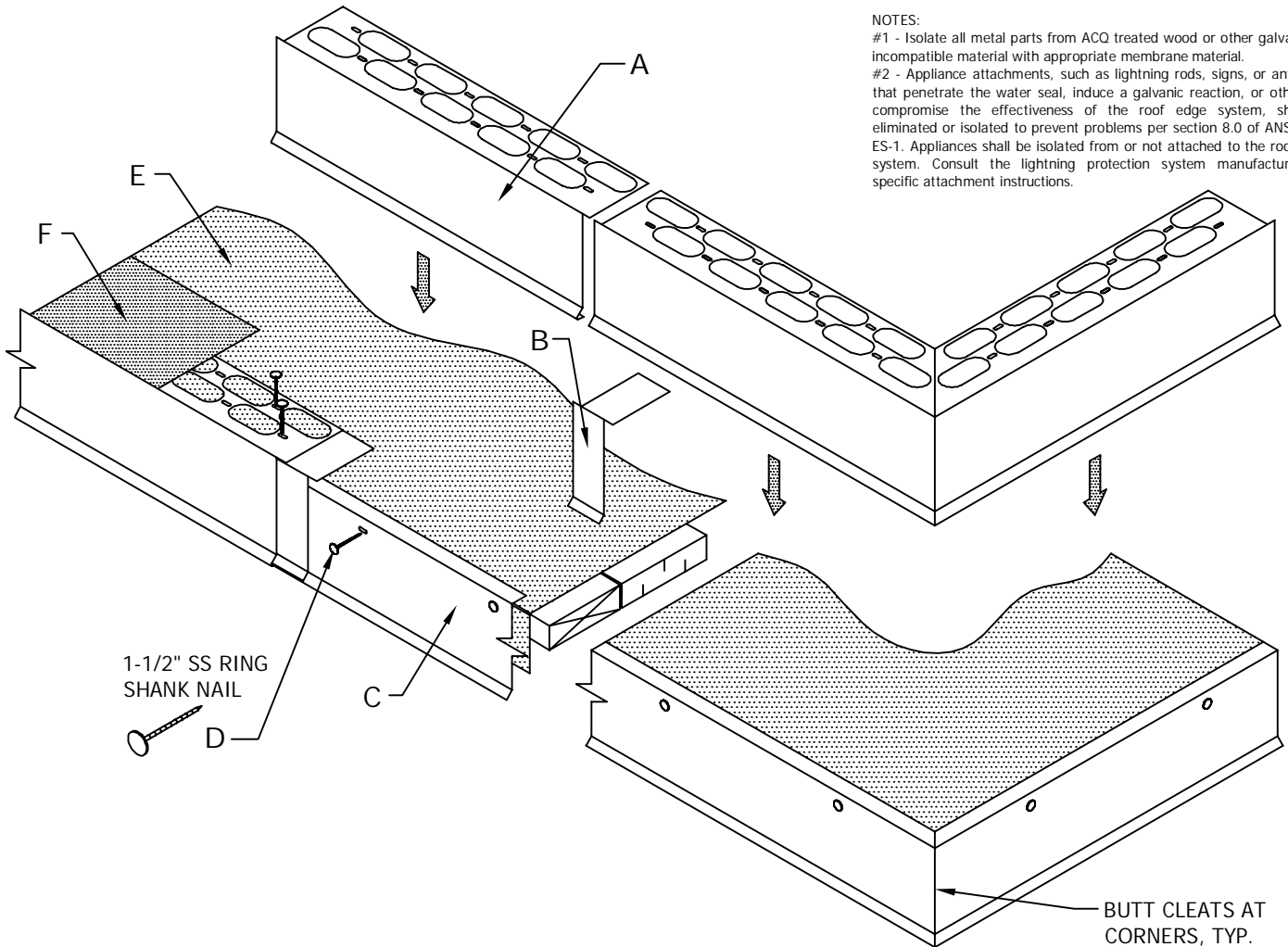

- A. Formed Fascia Cover  
10'-0" Lengths
- B. Concealed Joint Splice  
4" Lengths
- C. Galvanized Steel Anchor Cleat  
10'-0" Lengths

- D. 1-1/2" SS Ring Shank Nail  
at 12" o.c. (6" from ends)  
(Included & Required)
- E. Base Ply  
(By Installer)
- F. Strip-In or Cap Sheet  
(By Installer)

SOPREMA, Inc.  
310 Quadral Drive - Wadsworth, OH 44281 - Phone: (800) 356-3521 - Fax: (330) 334-4289

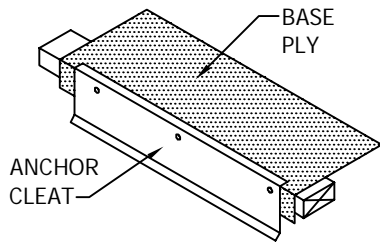

### STEP 1: Installing Anchor Cleat

Place the top lip of the continuous anchor cleat squarely on the top edge of the base ply and treated wood nailing plate. Press cleats securely in position and nail through the pre-punched holes with 1-1/2" ss ring shank nails provided. Install anchor cleats by butting cleats at each corner. For miter application, fit into corner as required to maintain a continuous anchor cleat line. Then nail at a min. 6" on center in each direction from the corner.

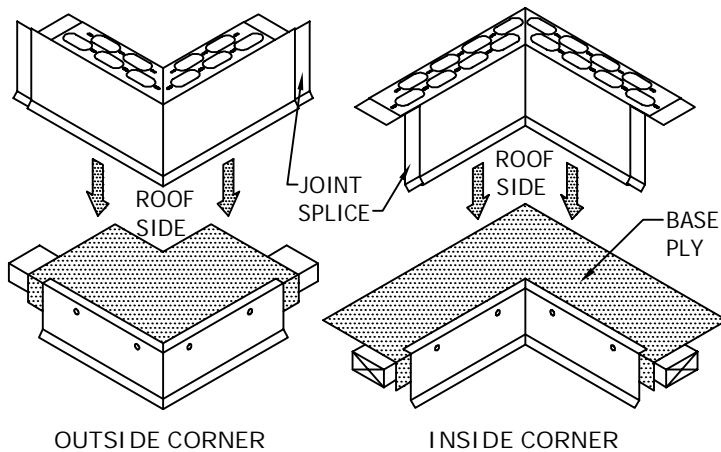

### STEP 2: Installing Fascia Miters

Locate the miters and concealed joint splices for the appropriate corners. Place a concealed joint splice under each end of the miter sections. Install the miter by hooking the drip of the fascia miter onto the drip of the cleat and rotate back onto the roof. Fasten with 1-1/2" ss ring shank nails provided in pre-punched holes.

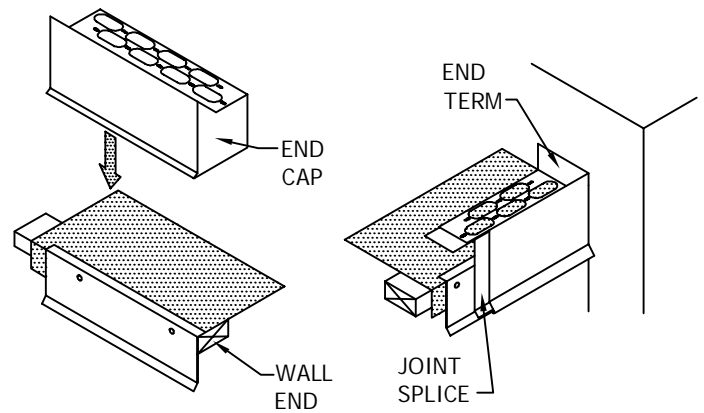

### STEP 3: Installing Fascia End Caps and End Terms

Install the fascia end caps and end terms by hooking the drip of the fascia onto the drip of the cleat and rotate back onto the roof. Fasten with 1-1/2" ss ring shank nails provided in pre-punched holes.

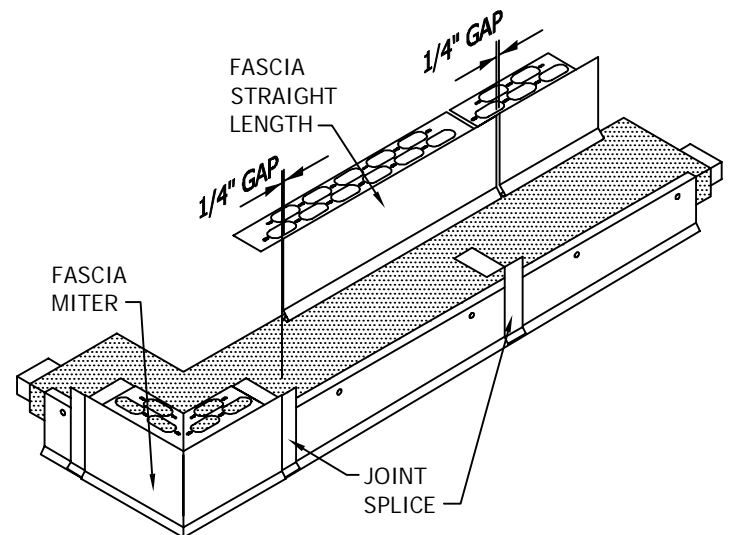

### STEP 4: Installing Fascia Straight Lengths

Place a concealed joint splice in the opposite end of the installed miter or end cap. Install the fascia by hooking the drip of the fascia onto the drip of the cleat and rotate back onto the roof. Fasten with 1-1/2" ss ring shank nails provided in pre-punched holes. Allow a 1/4" gap between fascia sections for thermal expansion. Consider lengths of all straight pieces prior to cutting to avoid creating relatively short sections of fascia adjacent to full length sections.

Note: there should be a joint splice at every joint.

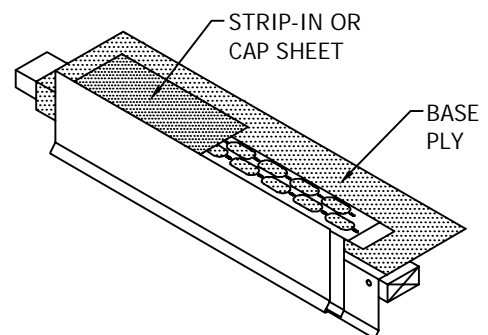

### STEP 5: Installing Strip-In or Cap Sheet

Install strip-in ply or cap sheet per roofing manufacturer's instructions.