

Colphene BSW Training and Application Guide

Colphene BSW Waterproofing Membrane.

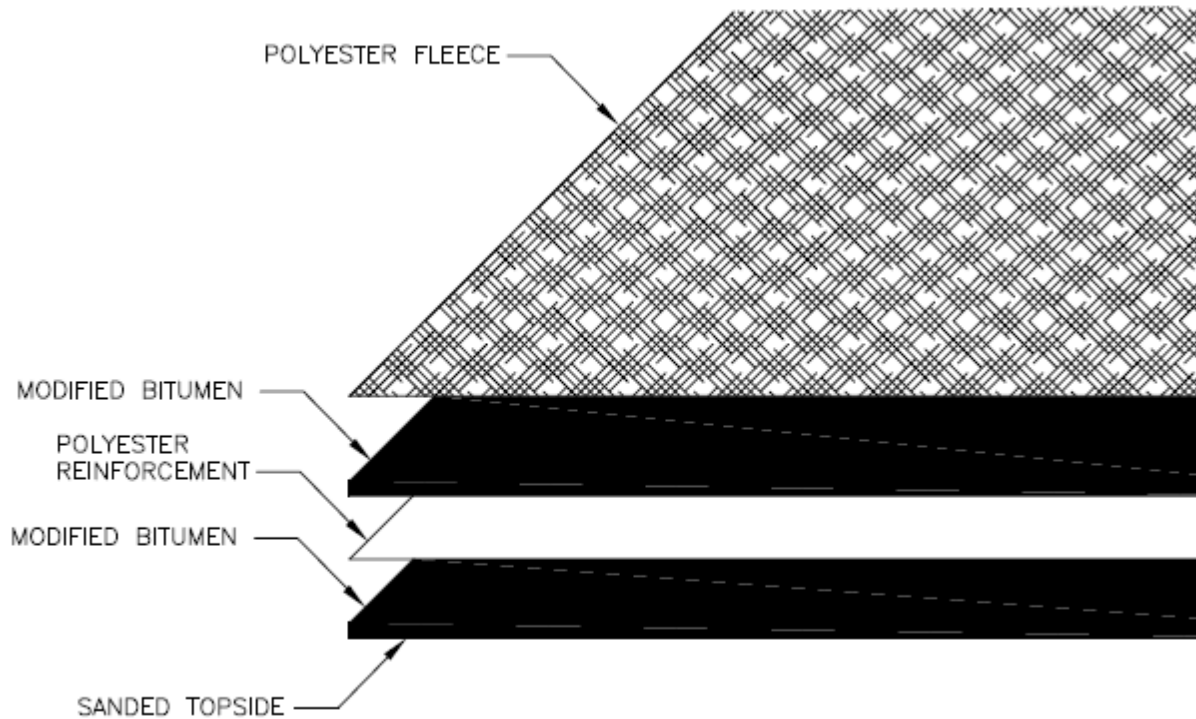

1. Prepare substrate

- Substrate must be structurally sound.
- Surface must be free of voids, spalled areas, loose aggregate, sharp protrusions.
- Remove all contaminants (such as grease, oil and wax) from all exposed surfaces.
- Remove dust, dirt, loose stone and debris (when dealing with a mud slab substrate).
- Use repair materials and methods which are acceptable to Soprema's sheet membrane waterproofing.
- Do not install materials in conditions of inclement weather.
- Verify the compatibility of all membrane components with curing compounds, coatings or other materials which are already installed on the surfaces to be treated.
- Verify substrate and drainage conditions meet or exceed the design of the Architect and Engineer of Record.

A. Cast In Place Concrete Substrates

- Verify Concrete has cured and aged for minimum time period.
- Horizontal slabs should be sloped for positive drainage.
- Repair substrate irregularities and imperfections.
- Ensure all concrete is smooth and free of voids.
- Grind irregular construction joints to suitable flush surface.
- Petroleum based products/ distillates are **not** to be used.

B. Soil Substrates

- Substrate must be dry, evenly and properly compacted and free of any possible contaminants and/or protrusions.
- Prepared substrate per Engineering requirements.

C. Wood Lagging Substrate

- Ensure all lagging boards are flush.
- Repair damaged lagging boards with concrete grout and/or treated wood.
- Gaps between lagging boards exceeding 1 inch will be filled or covered using concrete grout or plywood.

D. General

- Examine the substrates and other conditions under which this work is to be performed.
- Should any circumstances detrimental to the proper completion of the work, or deficiencies be determined, the Architect, Owner or General Contractor shall be given written notice of the unsatisfactory condition.
- Do not proceed with the installation of the specified waterproofing assembly until all surface deficiencies and unsatisfactory conditions have been corrected.

2. Drainage Board Installation

Current Specified Drainboards: Sopradrain ECO-Vent, Sopradrain ECO 2

A. Horizontal Installation

- Installation methods should be harmless to the waterproofing assembly.
- Install the specified drainage layer by loose laying the drain board onto the prepared substrate with the filter fabric facing the substrate.
- Cut the drainage panels to fit the surface (use caution not to damage the waterproofing assembly).
- Lap and tape edges and ends of geo-textile to maintain continuity, as required.

B. Vertical Installation

- Install the specified drainage layer by mechanically fastening to the wood lagging using Soprema approved fasteners.
- Place and secure prefabricated drainage panels with the filter fabric facing the wood lagging.
- Installation methods should be harmless to the waterproofing assembly.
- Lap and tape edges and ends of geo-textile to maintain continuity, as required.
- If required apply adhesive to adhere drainage layer (a 3" spot every 36").

3. Pre-treat All Details (with the exception of Inside Corners)

A. Control Joints, Construction joints, Cracks and expansion Joints

- Properly grout, seal and apply the appropriate water stop (as required).
- Ensure all materials are cured and functioning as the primary joint seal.
- Joint, control joints and any crack over 1/16" will be void free and reinforced with a bed of Colphene Liquid Membrane and a continuous strip of membrane extended a minimum of 6" past the cold joint(s)/crack(s) in all directions.
- As appropriate, a bead of Colphene Liquid Membrane will be applied to all perimeter edges of all reinforcement plies

B. Areas of potentially high substrate stress

These areas include interior and exterior corners, steel members (soldier piles), etc.

B.1 Steel Members (soldier piles)

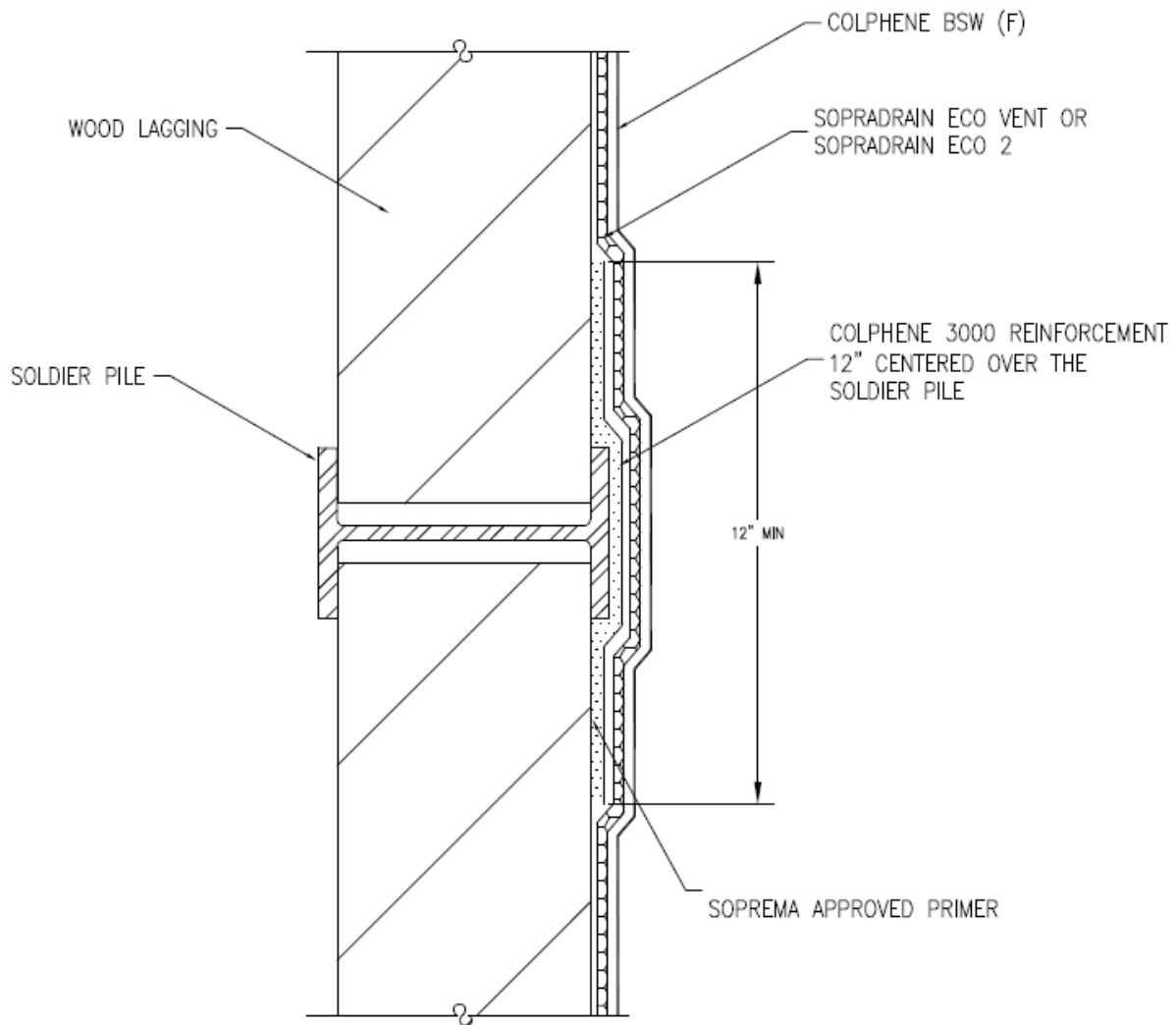

- Reinforcing strips of Colphene 3000 (or Colphene BSW) shall be applied in areas of potentially high substrate stress extending a minimum 6" on all sides (152mm), if Colphene BSW is used as a reinforcing strip it must be embedded in and caulked with Colphene Liquid Membrane.
- The sanded side of the Colphene BSW reinforcing strips will be adhered to the fleece side of the installed Colphene BSW membrane, embedded with a full trowel application of Colphene Liquid Membrane.
- Use hot air welder to remove fleece back prior to application of Liquid Membrane or alternate sealant.

B.2 Corners

- Outside corners will receive a 12" width of Colphene BSW or Colphene 3000 as reinforcement, wrapping the corner 6" in each direction embedded and caulked with Colphene Liquid Membrane.



- Corners must be tightly seated and sealed.
- Apply the field membrane fully covering the corner reinforcement membrane (two ply finished assembly).
- Inside corner target plies will be a 6" minimum circular shaped target ply patch embedded in and caulked with Colphene liquid membrane.
- Use hot air welder to remove fleece back prior to application of Liquid Membrane or alternate sealant.
- The inside corner target ply is installed after the Colphene BSW Field membrane.



4. Horizontal Application

- Prior to beginning work verify substrate and drainage conditions meet or exceed the design of the Architect and Engineer of Record.
- (If required, for Colphene 3000 reinforcement) Apply an appropriate primer at a rate recommended. Allow primer to dry per membrane manufacturer's recommendations prior to adhering to sanded surface of Colphene BSW (see PDS for recommended coverage rate and dry time).
- Install Colphene BSW membrane with sanded under face placed down against the surface of the specified Sopradrain drainage board.
- Remove the release paper on both sides of the self adhered side lap edges, adhering one to the other (fleece side selvage edge to sanded side selvage edge).
- Roll seams with an approved roller and hand pressure.
- Ensure that all laps are firmly adhered and that there are no voids or fishmouths.
- Subsequent rolls should be aligned with the preceding roll with a side lap of 4" (101mm).
- End laps must be overlapped a minimum 6" (152mm) and embedded in and caulked with Colphene Liquid Membrane.



- Use hot air welder to remove fleece back prior to application of Liquid Membrane or alternate sealant (Alsan RS 230 Flash is acceptable).
- Stagger end laps a minimum of 6".



- Membrane T-joints will receive a target patch of Colphene BSW centered over the T-joints and extending a minimum of 6" in all directions.
- T-joint target patch shall be embedded in and caulked with Colphene Liquid Membrane.
- Use hot air welder to remove fleece back prior to application of Liquid Membrane or alternate sealant.
- A hot air welder may need to be used on all self adhered side laps to create the proper heat and pressure to ensure all laps are firmly and smoothly adhered.

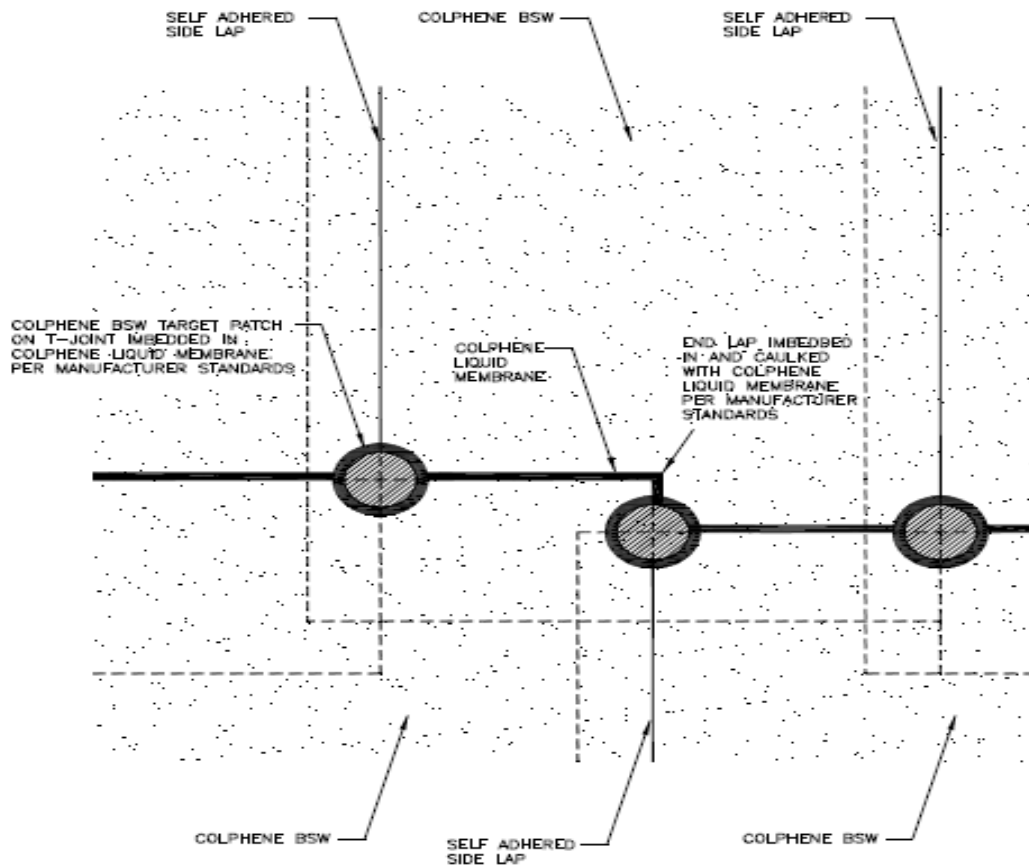

5. Vertical Application

- (If required, for Colphene 3000 reinforcement) Apply an appropriate primer at a rate recommended. Allow primer to dry per membrane manufacturer's recommendations prior to adhering to sanded surface of Colphene BSW (see PDS for recommended coverage rate and dry time).
- Starting at the high point, vertically align the Colphene BSW sheet, sanded under face toward the lag wall.
- Tack nail the Colphene BSW only at the top on the first 6" of the membrane (this will allow the tie-in to cover the tack nail penetrations).
- Remove the release paper on both sides of the self adhered side lap edges, adhering one to the other (fleece side selvage edge to sanded side selvage edge).
- Roll seams with an approved roller and hand pressure.
- Ensure all laps are firmly and smoothly adhered.
- Ensure no wrinkles, voids, fishmouths are present.
- As each floor is poured and the work continues up the vertical wall, remove tack nailing wherever possible ensuring holes are adequately sealed and lapped as required by Soprema standard details and specification.
- Subsequent rolls should be aligned with the preceding roll with a side lap of 4" (101mm).
- End laps must be overlapped a minimum 6" (152mm) and embedded in and caulked with Colphene Liquid Membrane.
- Use hot air welder to remove fleece back prior to application of Liquid Membrane or alternate sealant (Alsan RS 230 Flash is acceptable).
- A hot air welder may need to be used on all self adhered side laps in to create the proper heat and pressure to ensure all laps are firmly and smoothly adhered.
- Stagger end laps a minimum of 6".
- Membrane T-joints will receive a target patch of Colphene BSW centered over the T-joints and extending a minimum of 6" in all directions.
- T-joint target patch shall be embedded in and caulked with Colphene Liquid Membrane.
- Membrane shall be terminated in accordance with Soprema Approved Details
- The uppermost edge of the membrane shall be caulked with Sopramastic SM-1 or other approved sealant.
- Mechanically fasten Colphene BSW to the wood lagging using approved fasteners and termination bar.

- The termination bar will be set in a full bed of Sopramastic SM-1 (or approved mastic) and the top edge of the bar will be caulked with the same material.

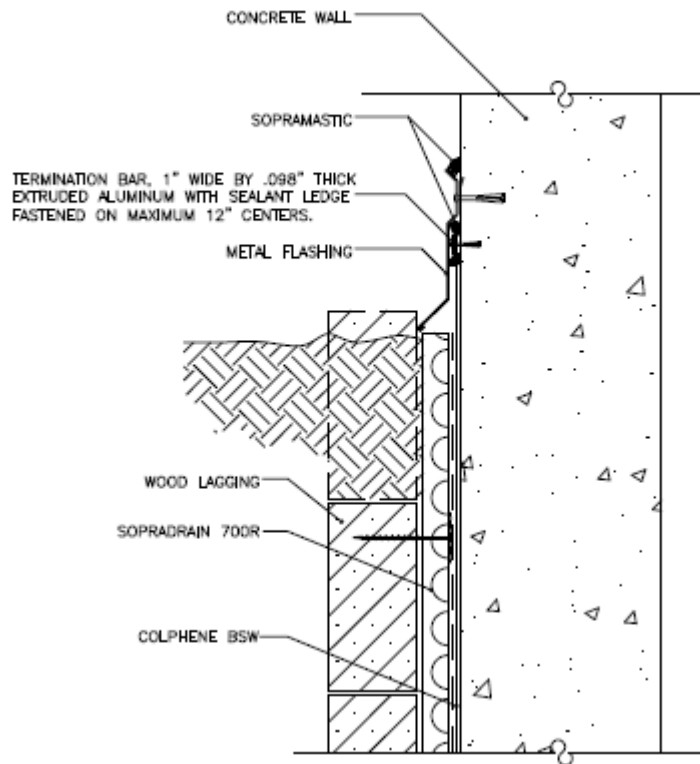

- All top of the wall cut edges in the field application will receive a bead of Sopramastic SM-1 (or approved mastic) at the end of the day's work

6. Work Inspection

A. Visual Work Inspection

- Review entire membrane installation.

A.1 Damaged Membrane

- If a damaged area is found, repair the damaged area by applying a repair/target patch of Colphene BSW or Colphene 3000 6" in all directions of the damaged area.
- Use hot air welder to remove fleece back prior to application of Liquid Membrane or alternate sealant.
- Apply repair patch imbedded in and caulked with Colphene Liquid Membrane (or Soprema approved alternate)
- Wrinkles and fishmouths will need to be cut and repaired as described above.



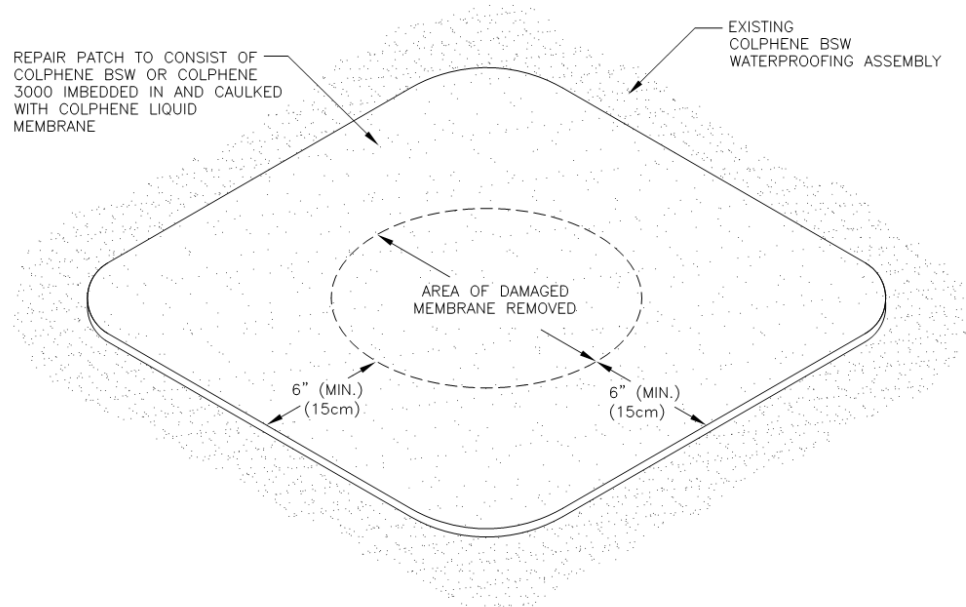

A.2 Insufficient Side Lap

- A minimum of 3" self adhered side lap must be maintained (Colphene BSW F is manufactured to provide a 4" side lap).
- If the side lap overlap is insufficient, burn off the fleece in the affected area using hot air welder
- Apply Colphene BSW repair patch extending a minimum of 6" on either side of the seam.
- Colphene BSW repair patch is imbedded in and caulked with Colphene Liquid Membrane

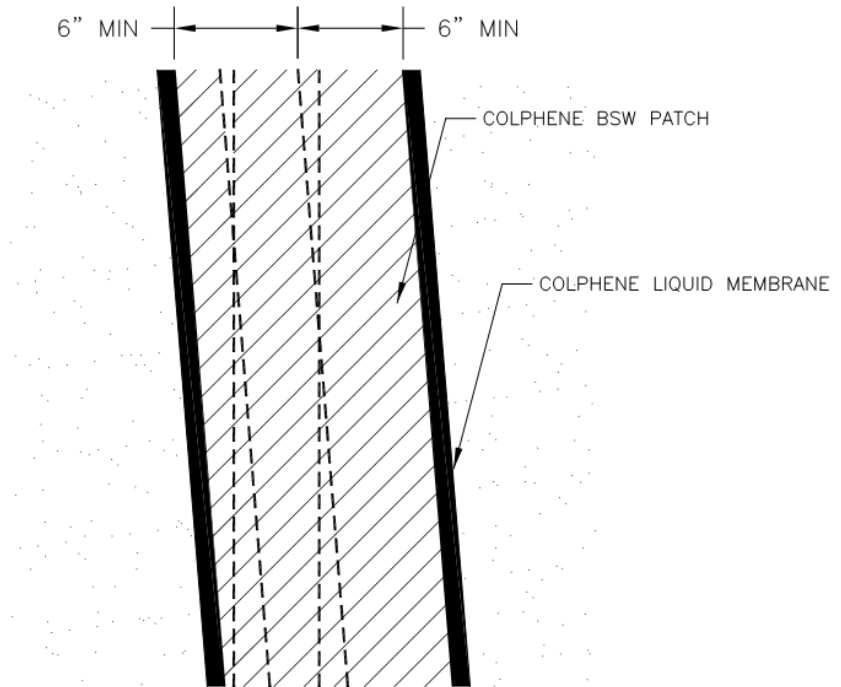
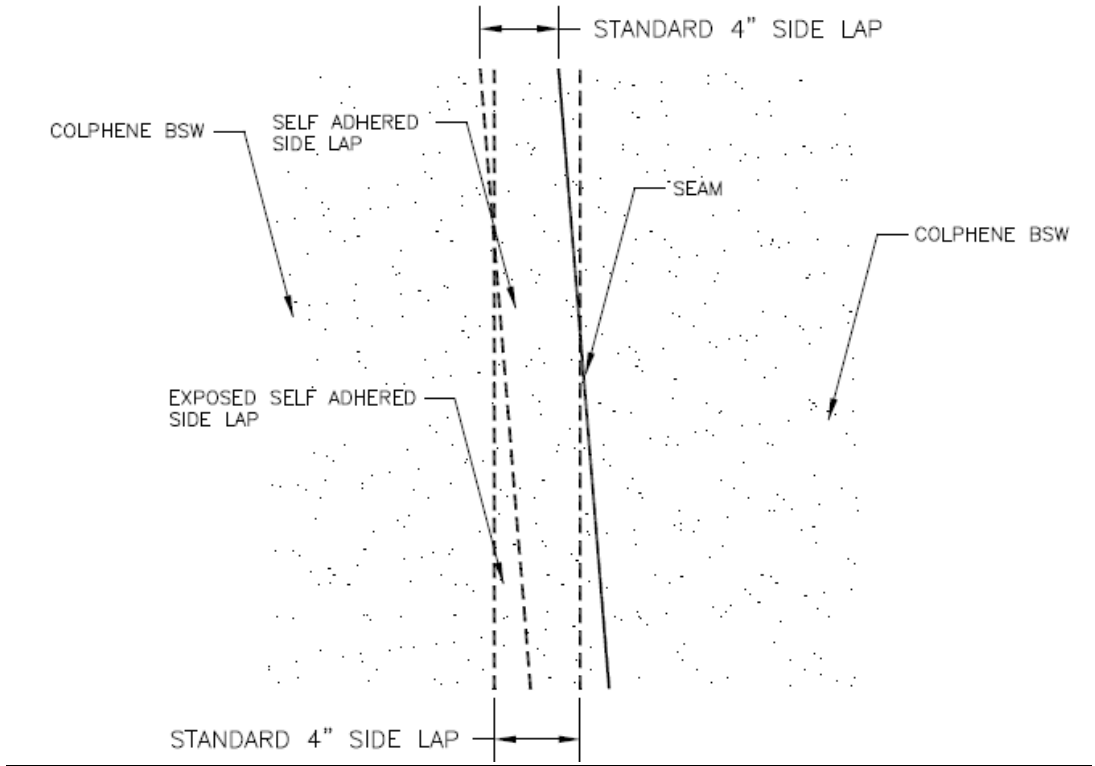



B. Water Test (rarely required for Blind Side Waterproofing)

- Flood test each deck area leaks (*ASTM D5957 Standard Guide for Flood Testing Horizontal Waterproofing Installations*) before overlaying construction is placed.
- VERIFY that the depth of water shall not exceed the load capacity of the deck.
- Flood to an average depth of 2-1/2 inches with a minimum depth of 1 inch and not exceeding a depth of 4 inches.
- Maintain 2 inches of clearance from top of flashing.
- Recommended flood time for each deck area is 48 hours.
- After flood testing, repair any leaks or damaged membrane.
- After repairs are made repeat flood test until the waterproofing installation is fully watertight.
- The Owner may engage an independent testing agency to observe flood testing procedures and results.
- Repair leaks and/or damaged membrane per the procedures defined above.

Note: *In lieu of flood testing, Soprema encourages Electronic Breach Detection as an acceptable alternative. Please contact Soprema for details.*

Colphene BSW Training and Application Guide (Cont.)

Colphene BSW Waterproofing Membrane.

7. Blind Side Waterproofing at Tie-Back

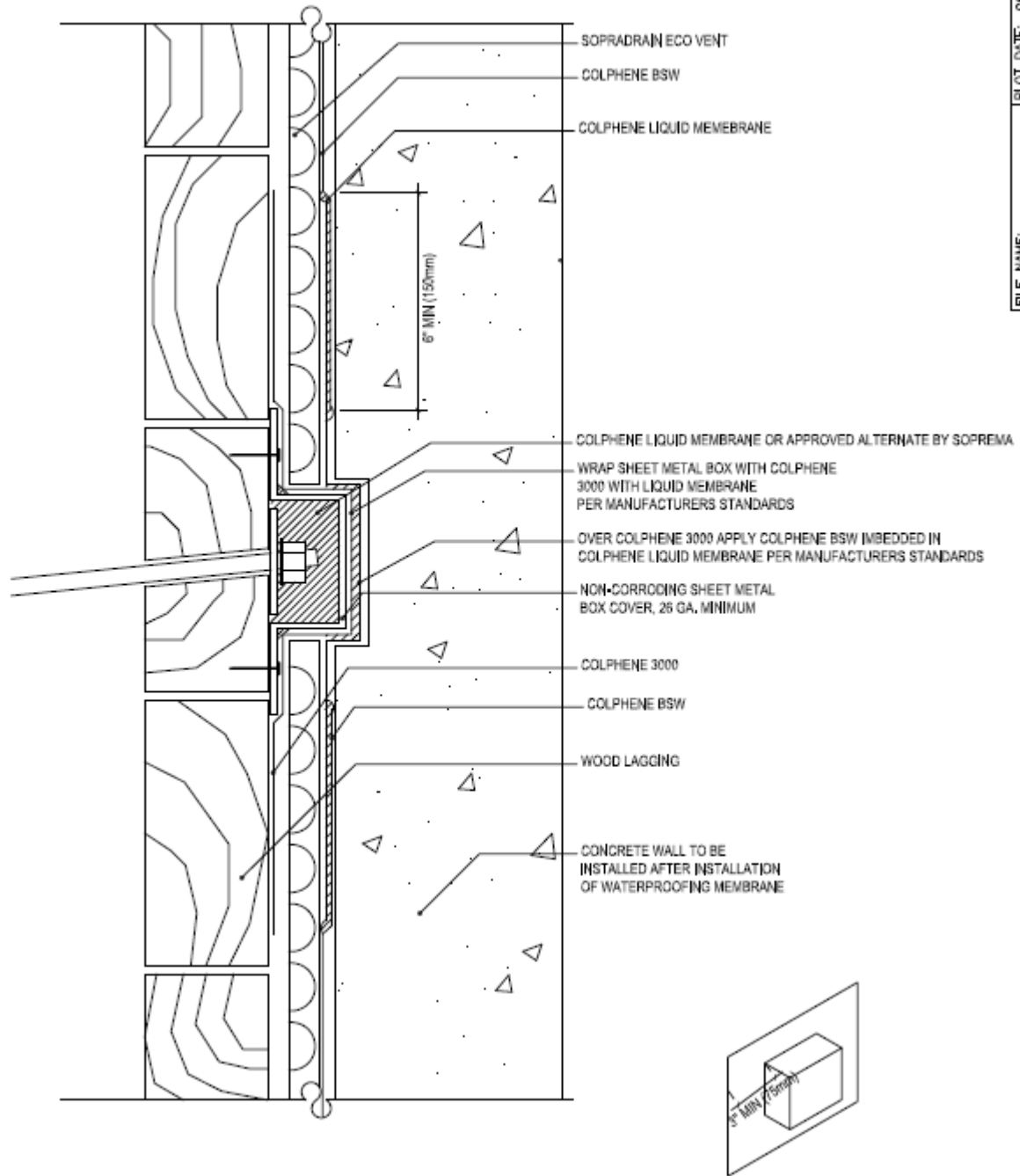

A. Surface Preparation

- Substrate must be structurally sound.
- Surface must be free of voids, spalled areas, loose aggregate and sharp protrusions.
- Remove all contaminates (such as grease, oil and wax) from all exposed surfaces.
- Use repair materials and methods which are acceptable to Soprema's sheet membrane waterproofing.
- Do not install materials in conditions of inclement weather.
- Verify the compatibility of all membrane components with curing compounds, coatings or other materials which are already installed on the surfaces to be treated.
- Verify substrate and drainage conditions meet or exceed the design of the Architect and Engineer of Record.

B. Surface Treatment

- Ensure all lagging boards are flush.
- Repair damaged lagging boards with concrete grout and/or treated wood.
- Gaps between lagging boards exceeding 1 inch will be filled or covered using concrete grout or plywood.

C. Detailing (per Soprema standard detail "BSW03")

- Install non-corroding sheet metal box cover (26 GA minimum) onto wood lagging and fill interior with Colphene Liquid Membrane (or Soprema approved alternate).
- Apply a bead of Colphene Liquid Membrane on the cover box angle change as shown in the above detail.
- Install Colphene 3000 reinforcement ply wrapping the box cover and extending a minimum of 6" on all sides onto the wood lagging.
- Install the specified drainage layer by mechanically fastening to the wood lagging using Soprema approved fasteners.
- Place and secure prefabricated drainage panels with the filter fabric facing the wood lagging.
- Installation methods should be harmless to the waterproofing assembly.
- Lap and tape edges and ends of geo-textile to maintain continuity as required.
- If required apply adhesive to adhere drainage layer (a 3" spot every 36").
- Install drainage layer to abut the non-corroding sheet metal box cover.
- Install Colphene BSW reinforcement ply over the Colphene 3000 reinforcement ply imbedded in Colphene liquid membrane.
- Colphene BSW reinforcement should extend a minimum of 6" from the cover box on all sides onto the specified drainage layer
- Install Colphene BSW field membrane

- Tie-in Colphene BSW field membrane to the Colphene BSW reinforcement ply a minimum of 6".
- The Colphene BSW tie-in is to be imbedded in and caulked with Colphene Liquid Membrane.
- Use hot air welder to remove fleece back prior to application of Liquid Membrane or alternate sealant.

8. Blind Side Waterproofing Penetrations.

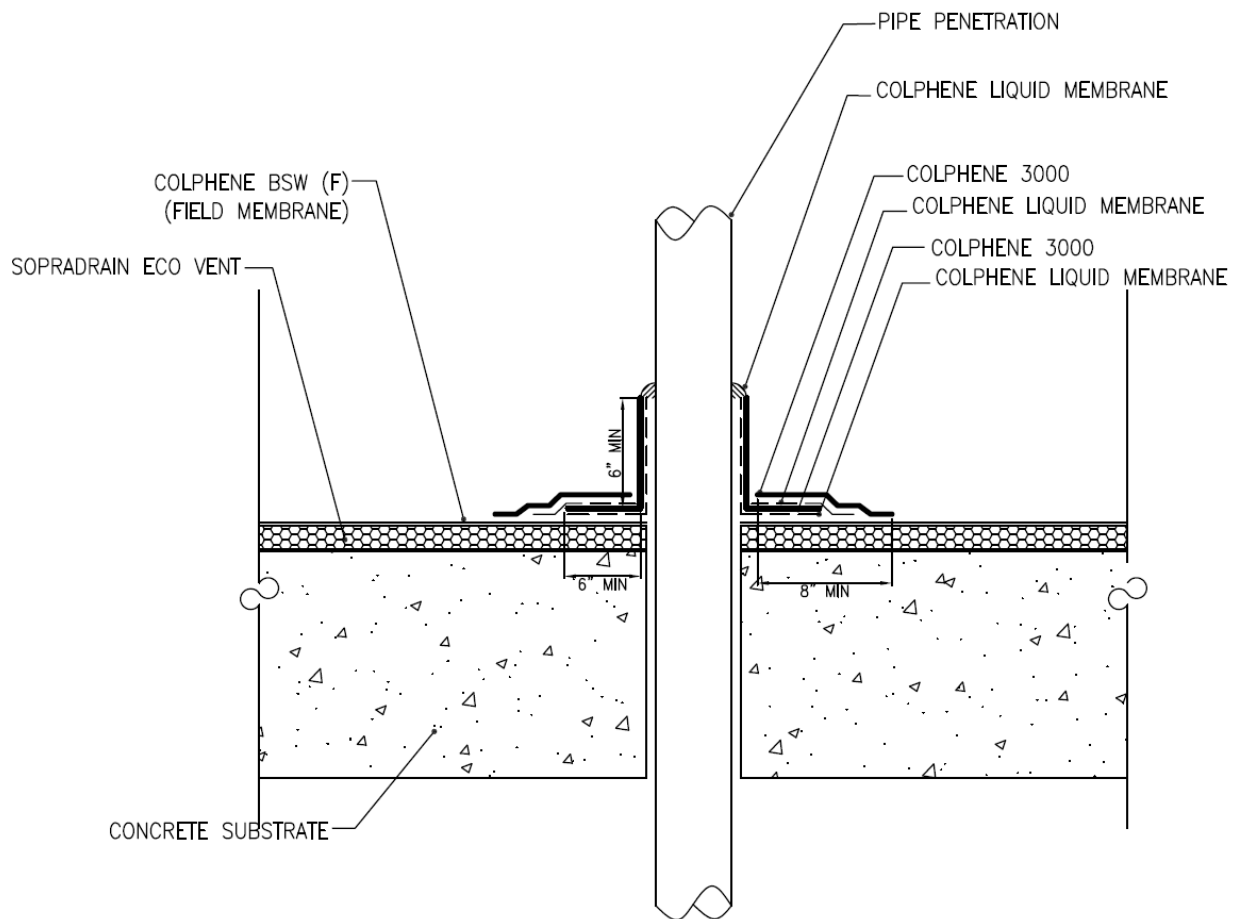

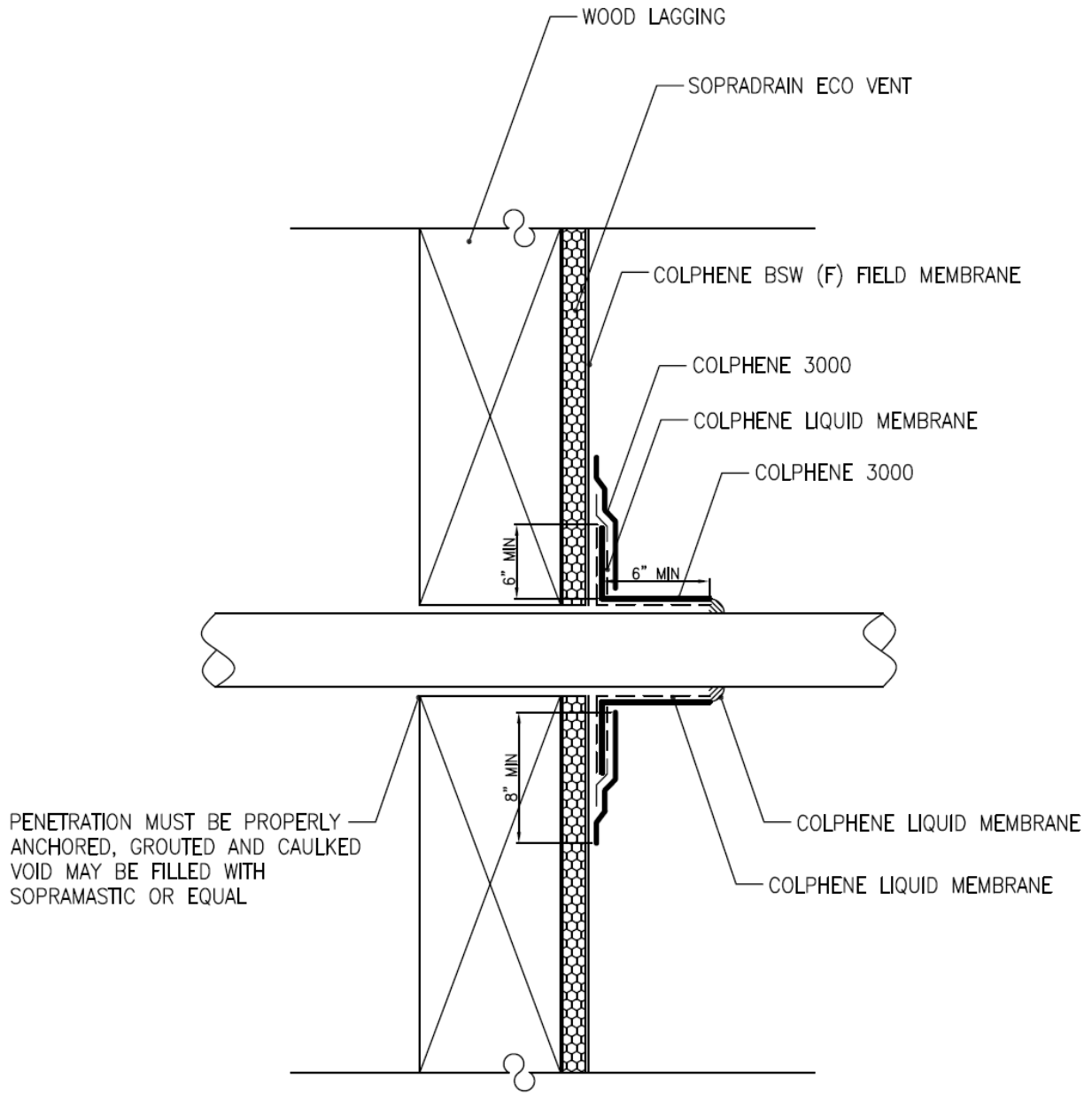

A. Surface Preparation

- Substrate must be structurally sound.
- Surface must be free of voids, spalled areas, loose aggregate and sharp protrusions.
- Remove all contaminants (such as grease, oil and wax) from all exposed surfaces.
- Use repair materials and methods which are acceptable to Soprema's sheet membrane waterproofing.
- Do not install materials in conditions of inclement weather.

- Verify the compatibility of all membrane components with curing compounds, coatings or other materials which are already installed on the surfaces to be treated.
- Verify substrate and drainage conditions meet or exceed the design of the Architect and Engineer of Record.

B. Surface Treatment

- Ensure all lagging boards are flush.
- Repair damaged lagging boards with concrete grout and/or treated wood.
Gaps between lagging boards exceeding 1 inch will be filled or covered using concrete grout or plywood
- Penetrations must be firmly secured/anchored and properly prepared prior to the installation of new materials.
- Apply Elastocol 600c primer as required.

D. Detailing (per Soprema standard detail "BSW10,11,12")

- Install Colphene 3000 reinforcement extending a minimum of 6" onto the BSW (F) field membrane and a minimum of 6" onto the properly prepared pipe penetration.
- The Colphene 3000 reinforcement is imbedded in and caulked with Colphene Liquid Membrane.
- Use hot air welder to remove fleece back prior to application of Liquid Membrane or alternate sealant.
- Install the second Colphene 3000 reinforcement with a minimum 6" tie-in to the first reinforcement ply and going a minimum of 2" onto the BSW (F) field membrane.
- The second Colphene 3000 reinforcement should be imbedded in and caulked with Colphene Liquid Membrane.
- Use hot air welder to remove fleece back prior to application of Liquid Membrane or alternate sealant.

