

FIELD (1 PER 2.3 FT²)

- ACTUAL ONE (1) FASTENER PER 2.22 SQUARE FEET
- NINE (9) FASTENERS PER BOARD
- ENSURE FASTENER ENGAGES THE TOP FLANGE FOR STEEL DECK APPLICATIONS

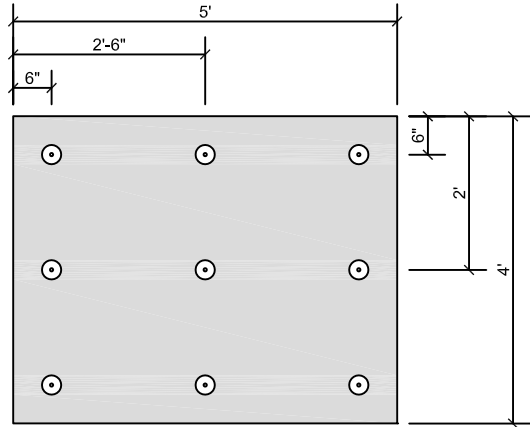

**PERIMETER
PRESCRIPTIVE ENHANCEMENT**

- ACTUAL ONE (1) FASTENER PER 1.33 SQUARE FEET
- FIFTEEN (15) FASTENERS PER BOARD
- ENSURE FASTENER ENGAGES THE TOP FLANGE FOR STEEL DECK APPLICATIONS

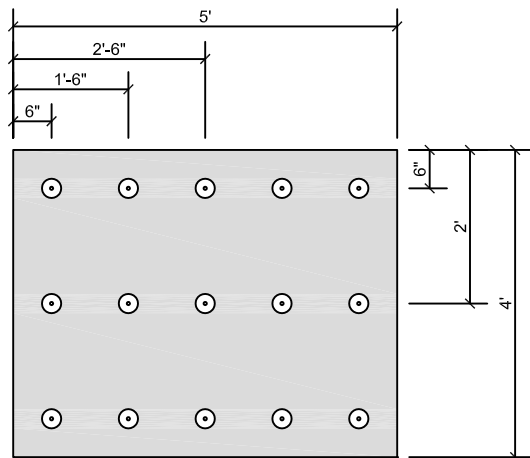

**CORNER
PRESCRIPTIVE ENHANCEMENT**

- ACTUAL ONE (1) FASTENER PER 1 SQUARE FOOT
- TWENTY (20) FASTENERS PER BOARD
- ENSURE FASTENER ENGAGES THE TOP FLANGE FOR STEEL DECK APPLICATIONS

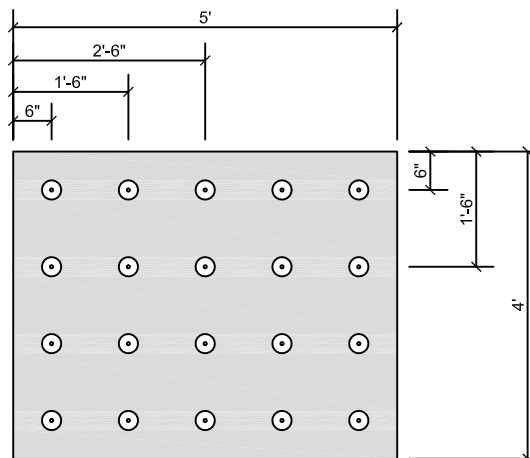

FASTENING PATTERNS AND ENHANCEMENTS SHOWN ARE FOR SOPREMA WARRANTY PURPOSES ONLY.



US CORPORATE ADDRESS
310 QUADRAL DRIVE
WADSWORTH, OHIO 44281
www.soprema.us
Tel:330.334.0066

PROJECT:

TITLE:

1 FASTENER PER 2.3 FT²,
4X5 BOARD FASTENING PATTERN

DRAWN BY: SOPREMA TECHNICAL SUPPORT, GGALLOWAY

NO.:

REVISION:

DATE:

DATE: 04.11.2014

SCALE: NTS

DRAWING NUMBER:
US.FP.03.03

USAGE OF THIS DETAIL IS GOVERNED BY THE TERMS OF SERVICE FOR SOPREMA DETAILS.
PLEASE CONSULT THESE TERMS OF SERVICE PRIOR TO UTILIZING THIS DRAWING.